

## How to create ZAC Jamb components in Spirit 14

A brief introduction about how the jamb component works in the new ZAC system.

A jamb in the ZAC system is used to define how the wall is cut where an opening (window or door) is inserted into the wall. The jamb consists of a single open polyline that defines how the wall will be cut and additional entities such as 2d lines, hatch and color fill and markers that define the actual jamb drawing.

In Spirit 12.31 and below, the jamb was associated to the window or door component being inserted into the wall. In spirit 14 the jambs for windows and doors are now associated to the ZAC wall component instead.

This ensures that no matter what opening component (door or window) is selected, it will always cut the wall correctly where these openings are inserted. The attribute dialog for zac wall components accommodates options to select a standard window and door jamb for the particular wall.



1. Start Spirit 14 and open the wall component for which you would like to generate a window or door jamb. (in this example we will use the 280mm cavity wall we created for generating zac wall components).
2. Select the *Draw* pull-down menu  $\rightarrow$  *Polyline*. Make sure that closed is unchecked. Now draw an open polyline by snapping to the bottom right corner of the wall polygon for the 1st point of the open polyline and then snap to the top right corner of the wall polygon for the 2nd and final point of the open polyline as shown below.

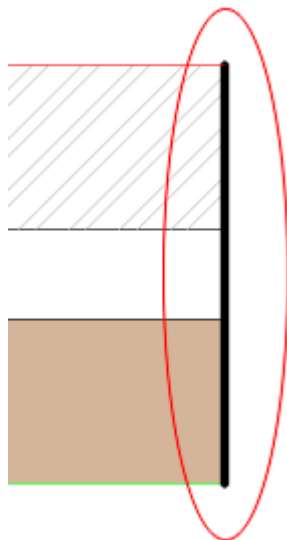

3. From the *Edit* pull-down menu select *Clipboard Select* (Ctrl + E). Activate *Area* in the *Add to Set* menu and then place an area around the polyline as shown.

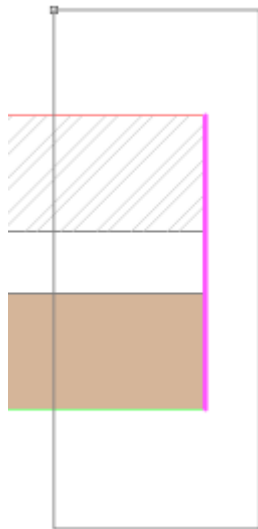

4. When selected, the polyline will be highlighted as shown above. Select the *Cut* option from the *UTILITY* menu.
5. Start a new Spirit drawing, changing the default drawing file to *ZAC\_Default-Window-Jamb\_Metric.zac* for metric components or *ZAC\_Default-Window-Jamb\_Imperial.zac* for imperial components.

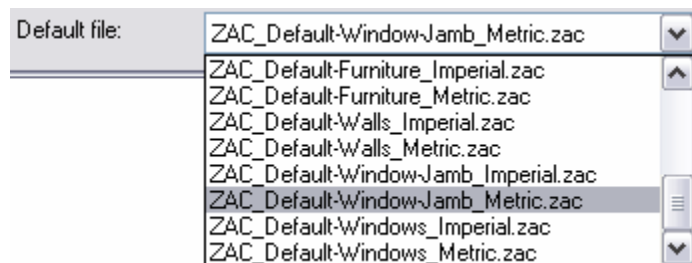

2. Select the folder to where you wish to save the new ZAC jamb component (the default folders for zac jamb components is *STI\SPIRIT\010\_ZAC Browser\030\_Window Jamb*s for window jambs and *STI\SPIRIT\010\_ZAC Browser\050\_Door Jamb*s for door jambs.)

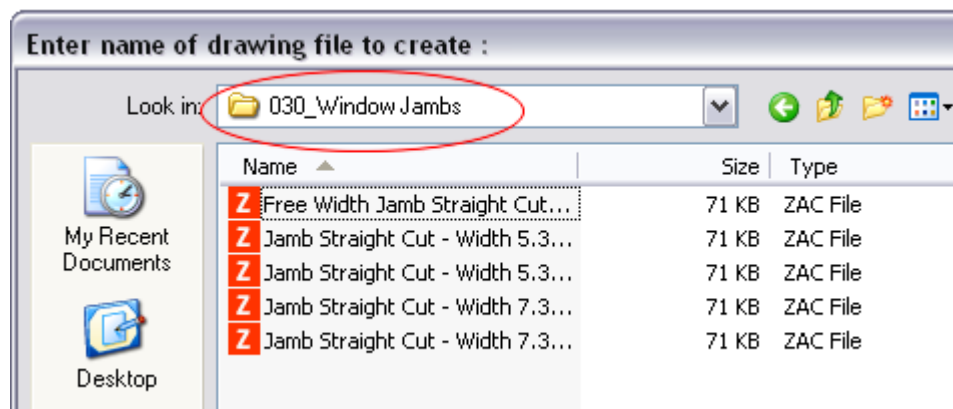

3. Enter the name of the new ZAC jamb component you wish to create and select the *Open* button.

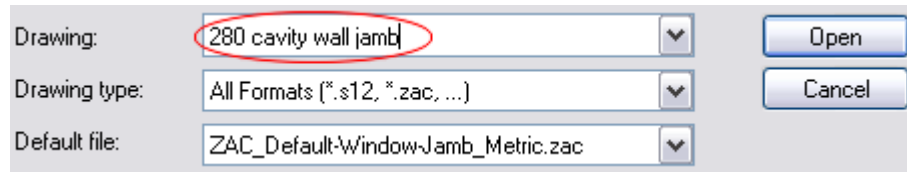

- The current active layer as shown in the status window is Plan-Low.

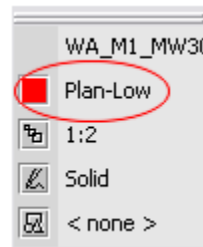

- Select the *Edit* pull-down menu  $\rightarrow$  *Paste*. Set active the option *Active Layer* and then select *Absolute Zero* from the *Paste* menu. This will paste the polyline at absolute zero on the layer Plan-Low.
- This polyline is used by the ZAC system to cut a straight line across the wall when inserting an opening. This is the most common jamb condition for the Low level of detail. However there is still one further operation to undertake for the drawing of the jamb detail for the low level of detail.
- The first thing you need to establish is the color in which the line will be drawn (you should coordinate this color with the actual wall color so that they appear with the same pen thickness if this is what you desire), the line type and overshoot value. Now select the *Draw* pull-down menu  $\rightarrow$  *Line* and draw a line over the polyline by snapping to the base point of the polyline and then snapping to the top point of the polyline. This is what the actual jamb will look like when used with the window component and inserted into the 280mm cavity wall at a low level of detail.



- The sill extension shown in the image above is achieved by adding a small vertical line the extent of the offset of the sill (in this case 50mm) to the top of the vertical line drawn in 7 above. It is drawn in a different line color to the line drawn in 7 above, to distinguish its pen thickness from that of the line used for the main cut across the wall. To get the horizontal line of the external sill drawn across the window a special case exists for ZAC jambs where you use a marker. Spirit will then generate a horizontal line from the one jamb to the other wherever these markers occur. You can even assign a line type to these markers that is then transferred to the horizontal line drawn. An overshoot value of 50mm has also been applied to the markers and vertical sill extension line. You can access the menu for drawing markers by selecting the *Model* pull-down menu  $\rightarrow$  *Marker*.
- You could now copy this jamb drawing to each of the other layers for the respective levels of detail. However for the other levels of detail we more than likely would show more detail with respect to the jamb which would entail a slightly different approach. In the example shown below for the high level of detail we will now explain in detail how this is achieved.



10. Lets begin now by setting active the Plan-High layer. Select *Plan-Low* in the status window and then select *Plan-High* from the *Set Active* menu.
11. We will now construct the polyline for the wall cut. Select the *Draw* pull-down menu  $\Rightarrow$  *Polyline*. (You can now also select the *ZAC* pull-down menu  $\Rightarrow$  *Wall Separation line* option). Uncheck *Closed* if it is currently checked.
12. Select the *Tools* pull-down menu  $\Rightarrow$  *Input mode* and select *Relative Polar*.

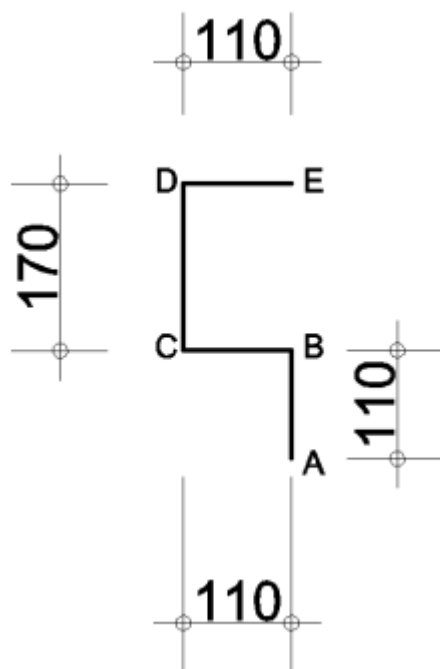

13. Snap to the bottom of the existing polyline for the start point of the new polyline (Point A). To draw the first leg of the polyline from point A to point B, enter a value of 110 and 90. To draw the second leg of the polyline from point B to Point C enter a value of 110 and 180. For the third leg of the polyline from point C to point D enter a value of 170 and 90. For the fourth and last leg of the polyline from point D to point E enter a value of 110 and 0. Right click to exit the polyline drawing operation.
14. We will now activate only the Plan-High layer. To do this select the *View* pull-down menu  $\Rightarrow$  *Layers*. Select *Active Only* from the *Layers* menu and select *Plan-High*. Right click once to exit the *Active Only* menu.

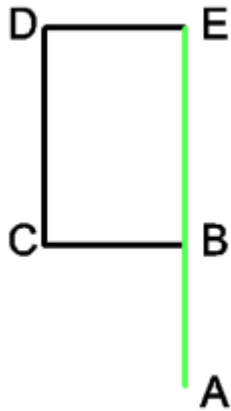

15. Change the current color for the line to be drawn to the same color as the line drawn for the exterior wall line. This will generate the same pen thickness for the exterior wall line and jamb if this is what you require
16. Select the *Draw* pull-down menu  $\rightarrow$  *Line*. Snap to point A for the start point of the line and to point E for the end point of the line.

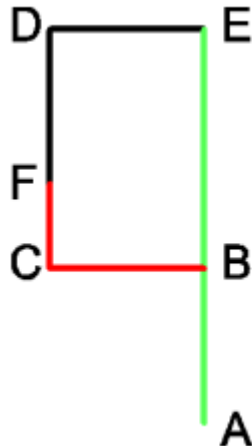

17. Change the current color for the next jamb lines to be drawn to match the internal lines of the cavity wall if this is desired. Select the *Draw* pull-down menu and snap to point B for the start point of the next jamb line. Now snap to Point C for the end point of this line. Enter a value of 60 and 90 for the next jamb line drawn from point C to point F. This completes the line drawing for the jamb for detail high.

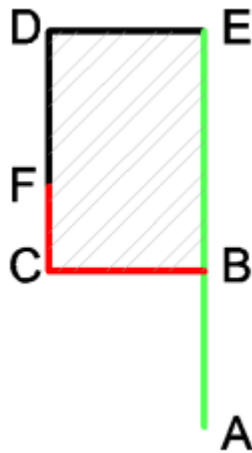

18. We will now add the wall hatch to the jamb. Select the *Draw* pull-down menu  $\rightarrow$  *Hatch*. (You can now also select the *ZAC* pull-down menu  $\rightarrow$  *Hatch Supplement* option). Activate *Associative* and *No Outline*. Select the *Color* option and select a color for the hatch. This color is independent of the current cursor color. In general this color should match the color of the wall hatch. Select *Factor* and enter a value of 10. Select *Pattern* and select *Ansi32*. Select *Origin* and snap to point A for the hatch origin. This is a critical step in getting the jamb hatch and wall hatch to align - the same hatch origin **MUST** be used for both which in this case is the absolute origin. Select *Boundary*, activate *Rectangle* and snap to point C for the first corner of the rectangle boundary and then snap to point E for the second corner of the rectangle boundary.

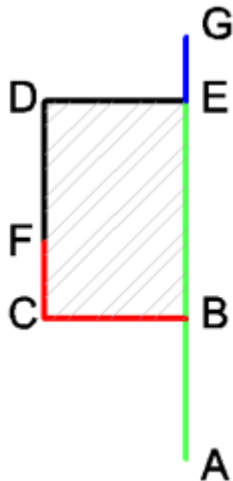

19. Change the current line color and overshoot values for drawing the exterior sill extension line (Point E to Point G). Select the *Draw* pull-down menu  $\rightarrow$  *Line*. Snap to point E for the start point of the line and then enter a value of 50 and 90.

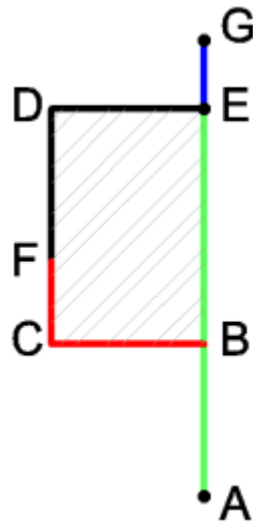

20. Set the line-type, color and overshoot values for the horizontal sill line. Select the *Model* pull-down menu *Marker*. (You can now also select the *ZAC* pull-down menu *Connector* option). Snap a marker at point G, point E and point A. The marker at point G will draw the exterior sill line across the window. This is generally a solid line. The marker at point E will draw the wall line under the sill, generally in a dashed line. To create a dashed line, select the *Edit* pull-down menu *Change*. Select *Line Type* and select *Dashed*. Set selection mode to *Area* and place an area rectangle over the marker at point E. The marker at point A will draw the interior sill line flush with the interior wall surface. This is generally a solid line.
21. You can now copy the current drawing data for the high level of detail to the respective layers for Standard and Medium level of details. To do this select the *Edit* pull-down menu *Copy*. Select *To Layer* from the Copy menu and select *Plan-Standard*. Pick a point anywhere on screen and then select the *All* menu option. Perform the same operation again for copying the data to the Plan-Medium layer.
22. You can now activate only the Plan-Standard and Plan-Medium layers and remove or edit data for the respective level of detail. Generally you would want to change the hatch factor for the wall jamb hatch for the various levels of detail and perhaps make some other edits.
23. This completes the construction of the ZAC window jamb. You can now select the *ZAC* pull-down menu *Test ZAC Component* option to check and correct the integrity of the jamb component.
24. To the right of the SPIRIT drawing screen in the Data Selection dialog, you will find the attribute data for the window jamb. Here you can enter a hinge depth value, which is an offset value for the window or door component from the outside edge of the wall surface. (i.e an offset value from point A on the window jamb). You can also enter a textual description for the window jamb that will appear as a tooltip when you hover over the component in the new Browser.
25. Lastly, select the *File* pull-down menu and select *Save*.

#### NOTE:

Once the jamb component has been generated and saved, don't forget to open the corresponding wall component and select this jamb component in the entry provided for Standard Window jamb in the attribute data for the window.